

WSN and M2M for cycling performance assessment

José Barreiro

Instituto de Telecomunicações /
ISCTE-IUL
Lisboa, Portugal
Jose_Barreiro@iscte-iul.pt

Octavian Postolache

Instituto de Telecomunicações /
ISCTE-IUL
Lisboa, Portugal
opostolache@lx.it.pt

Pedro Passos

CIPER
FMH
Lisboa, Portugal
passos.p@gmail.com

Abstract — Cycling assessment to increase performance during sport training is an important issue. In this article presents a wireless sensor network including multi-sensing channels for dynamic and cinematic measurement during cycling training. The Smart Mountain Bike is a system that includes the bicycle and the associated sports equipment, such as gloves, shoes and chest strap. The system is characterized by sensing channels as part of wireless sensor network which base station is expressed by embedded computer and a 3G/UMTS shield which permit the data communication with a cloud server. The data stored on the server is accessed through a mobile application that analyzes and correlates all user information and allows data visualization with a friendly graphical interface.

Keywords - wireless sensor network, machine-to-machine, bicycle, cloud computing, mobile application

I. INTRODUCTION

Mountain bikes are typically ridden on single track trails and other unpaved environments. These types of terrain commonly include rocks, loose gravel, roots, and steep grades (both inclines and declines) which demands a continuously adaptation from the rider aiming to achieve a tiny balance between speed and safety. Mountain bikes are built to handle this terrain and the obstacles that are found in it like logs, vertical drop offs, and smaller boulders. Along the trail the rider controls the bike through the hands, feet and body positioning. Thus going down a track in mountain bike demands a close interaction between rider and bicycle which is highly constrained by external factors such as the track slope and obstacles. It is that interactive behavior between bicycle and rider that we aim to capture, using IMU and force sensors as part of wireless sensor network (WSN). For that purpose on a first stage data collection is performed using the following variables: i) braking intensity; ii) braking frequency; iii) pedal strength; iv) rider body positioning; v) bicycle oscillations on the three plans of motion. These variables allow calculate coordinative variables to describe rider – bicycle interactions.

Training is critical to the performance of any athlete, whether professional or recreational. The "Smart Mountain Bike" system will allow recreational practitioners, as well as athletes and their respective coaches to obtain new performance data and consecutively adapt the training methods and improve sports performance.

II. RELATED WORK

Cycling is a complex physical activity that involves a broad set of movements. This movement can be studied using instrumented bikes [1]. The placement of sensors on the bike parts and equipment allows us to collect other information such as the applied force and accelerations. This type of study allows the creation of models that describe the movement and balance. Research in this field especially related to analysis of synchronous braking on a bicycle are reported in [2].

In recent years, advances in wireless sensor networks (WSN) have facilitated the use of these networks for monitoring applications, and there are some low-cost frameworks used as [3], [4]. One of the areas on the rise is the monitoring of indoor [5] and outdoor [6] environmental conditions, and other area is the monitoring of the human body in various disciplines such as health monitoring [7] or analyzing sports performance [8].

Another expanding area is communication Machine-to-Machine (M2M) [9], [10] mainly due to mass use of the Internet and the ability to connect new devices to the network, this leads us to the evolution of the Internet of Things (IoT) and the creation of new opportunities and challenges [11]. In is scenario, Cloud Computing [12] is a new paradigm that provides computing power, storage and software services and a scalable virtualized manner.

Joining WSN and Cloud Computing, the Sensor-Cloud architecture arises. This architecture allows to store and process the sensor data in accessible form, available timely, and cost-effective [13] [7]. It also allows easier integration with new mobile devices like tablets or smartphones through customized mobile applications that can collect process and display all sensor data.

Currently thousands of mobile applications are placed on the market every day [14], some of these apps are related to the use of bicycles and cycling but, most of these only collect information via mobile phone modules (GPS, accelerometer and gyroscope) and in some cases also through a Bluetooth external heartbeat sensor [15].

In this context, the paper presents a system that collects data on cycling activity through a WSN sending the primary processed data via M2M communication, stores them in the cloud, and analyzes them through a mobile application.

III. SMART MOUNTAIN BIKE: OVERVIEW

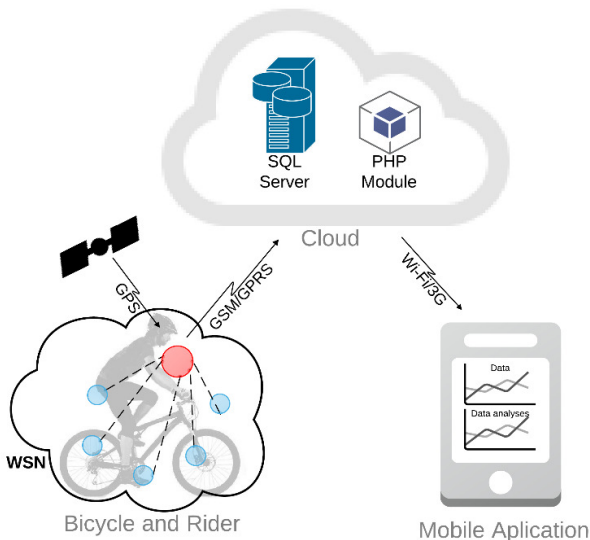

Figure 1 - System overview. A) Bicycle and Rider include data collection through WSN and GPS receiver. B) Cloud storage with a SQL server. C) Mobile Application to visualize and analyze cloud-sensor data.

The “Smart Mountain Bike” system consists of three blocks (Fig. 1). The first, called Bicycle and Rider consists of a wireless sensors network where sensors are placed on sports equipment such as gloves, shoes, chest strap and bicycle frame. Each of the end nodes have an ATmega328P microcontroller to make the acquisition and processing of primary data, this is then sent to the network core that consists of an embedded computer that handles the communication with the server that materialize the cloud. The second block consists of a server with a SQL database to ensure the storage of all information collected and to perform the advanced signal processing of the data. Finally, the data allocated on the server is accessed through a mobile application, developed for Android OS that analyzes and correlates all user information and allows data visualization through a friendly graphical user interface.

IV. SMART MOUNTAIN BIKE: HARDWARE

The WSN hardware responsible for the acquisition, processing and delivery of data to the cloud are force sensors, inertial measurement units including 3G accelerometer [16], microcontrollers [17] and embedded computer [18].

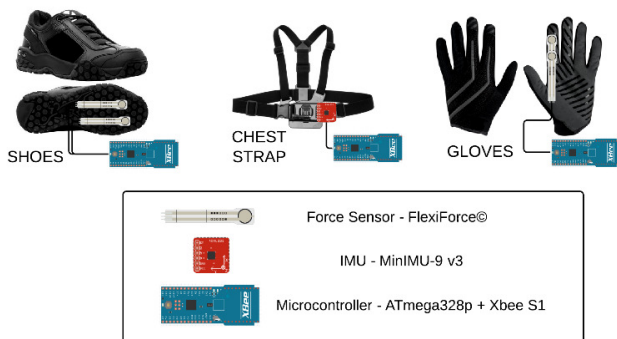

Figure 2 – Sensors and Microcontroller nodes

A. Sensors and conditioning circuits

1) Force sensors

The used force sensor (Figure 3) is expressed by a flexible piezoresistor sensor that is used as part of a voltage divider. When the force sensor is unloaded, its resistance is very high the output of conditioning circuit being zero while when a force is applied to the sensor, the sensor resistance decrease [19].

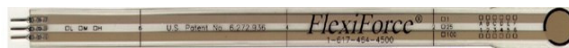

Figure 3 – Force Sensor FlexiForce® a201 100lbs

These sensors are used in gloves and shoes to measure the force applied to the brakes and pedals respectively. The conditioning circuit is presented in Figure 4.

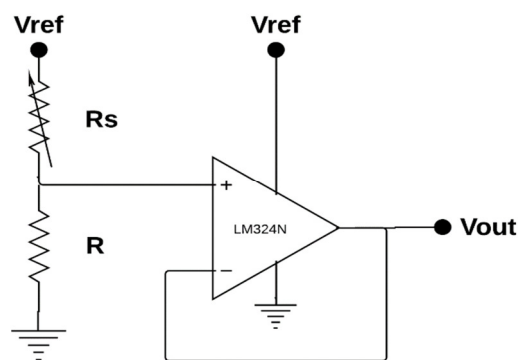

Figure 4 - Conditioning circuit for force sensors (RS-sensor resistance, R-reference resistance)

The conditioning circuit output voltage is given by:

$$V_{out} = \frac{R}{R_s + R} \times V_{ref} \quad (1)$$

where, the parameters in equation (1) are defined as follows:

- Vref: is the reference voltage [V];
- Rs: is the variable resistance, force sensor [Ω];
- R: is the reference resistor [Ω];
- Vout: is the output voltage [V];

Referring to the used flexiforce sensors to measure the force on the impact points during the braking actions mechanical adaptation embedded on the gloves were developed the performance on force measurement being underlined in the results of the papers.

2) Inertial measurement unit

IMU, is an electronic device that measures and reports velocity, orientation, and gravitational forces, using a combination of accelerometers, gyroscopes and magnetometer. The Pololu MinIMU-9 v3 used (Figure 5) is a compact board that combines ST’s L3GD20H 3-axis gyroscope and

LSM303D 3-axis accelerometer and 3-axis magnetometer to form an inertial measurement unit (IMU).



Figure 5 - Pololu - MinIMU-9 v3

The nine independent rotation, acceleration, and magnetic readings (sometimes called 9 Degrees of Freedom) provide all the data needed to make an attitude and heading reference system (AHRS). AHRS consists of sensors on three axes that provide heading, attitude and yaw information.

These sensors are attached to the chest strap and measure the upper body motion. Attached to the bicycle frame, it permits to monitor bicycle oscillations on the three plans of motion. The IMU, L3GD20H's gyro and the LSM303D's accelerometer and magnetometer can be queried and configured through the I²C bus. Each of the three sensors acts as a slave device on the same I²C bus.

B. Embedded systems

The ATmega328P is a high-performance Atmel picoPower 8-bit AVR RISC-based microcontroller. This device achieves throughputs approaching 1 MIPS per MHz, balancing power consumption and processing speed [17].

Each microcontroller is responsible for the acquisition of sensor data (Figure 2), primary processing and communication of data to the network coordinator. The communication between the network nodes is done through a network Zig Bee, for that we have an XBee® 802.15.4 [20] module coupled to each microcontroller and to the embedded computer.

IEEE 802.15.4/ ZigBee sensor network support low power consumption and node expansion compared to other network standards for WSN [21]. As can be seen in the Figure 6, the network has a star topology, in which the embedded computer placed in bicycle frame represents the WSN coordinator.

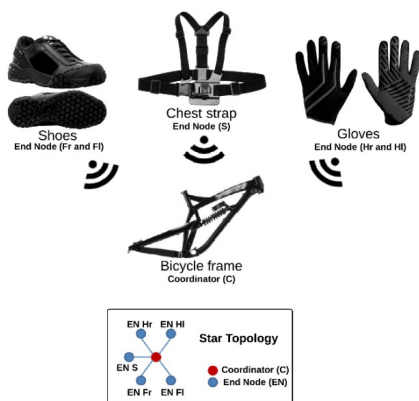

Figure 6 – WSN star topology. Coordinator placed in bicycle frame. End nodes placed in shoes, chest strap and gloves.

C. Embedded computer

The central network node located in the bicycle frame it is materialized by an embedded computer BEAGLEBONE Black with a 1GHz AM335x ARM® Cortex-A8 processor from Texas Instruments Incorporated [18]. It also has a GPS / GPRS Cape that adds GPS and GSM/GPRS capabilities to the BeagleBone for tracking and M2M communication. The cape uses the Telit GE864 module and supports the Quad band GSM/GPRS (850MHz, 900MHz, 1800MHz and 1900MHz). Coupled to the embedded computer is also an IMU (IV.A.2) for measurement of bicycle frame oscillations on the three plans of motion.

V. SMART MOUNTAIN BIKE: SYSTEM SOFTWARE

Referring the software components several components are mentioned: the embedded microcontroller and microcomputer software, the database software that handles requests to the database and the mobile device software.

A. Embedded software for microcontroller

The microcontroller is programmed using C compiler language and several Arduino libraries. The used data acquisition rate is 20samples/s. Depending on the type of sensor have different ways of collecting and processing the data are mentioned:

- In the case of force sensors, V_{out} (1) is the read voltage at the analog input pin and its value (between 0 and 1023 due to analog-to-digital converter) is converted to a value of strength in Kg [22]. This conversion is expressed by the equation (2):

$$F(V_{out}) = 10.56 * \left(\frac{adc_{value}}{4096 * 2.5} \right) \quad (2)$$

The $F(V_{out})$ conversion in SI force units is given by (3):

$$F(V_{out})[N] = F(V_{out})[Kg] * 9.8 \quad (3)$$

- In the case of the IMU, the L3GD20H and LSM303D each have separate slave addresses on the I²C bus. *Pololu* has written a basic L3GD20 and LSM303 Arduino library that allows the reading of the gyroscope, accelerometer and magnetometer registers therefore there is not necessary additional calculations in the microcontroller.

The processed data is sent to the central node of the WSN with its identifier.

B. Microcomputer embedded software

The microcomputer runs an Angstrom Linux operating system and is programmed using node.js and *bonescript* library.

This module gathers information from the IMU, GPS module and all other nodes in WSN, and establishes communication to cloud, to write the data in the database.

C. Cloud software

In the cloud we have two modules, SQL server with database and a module for PHP functions.

The database stores all the information about the user and his training, we have implemented the following model (Figure 7).

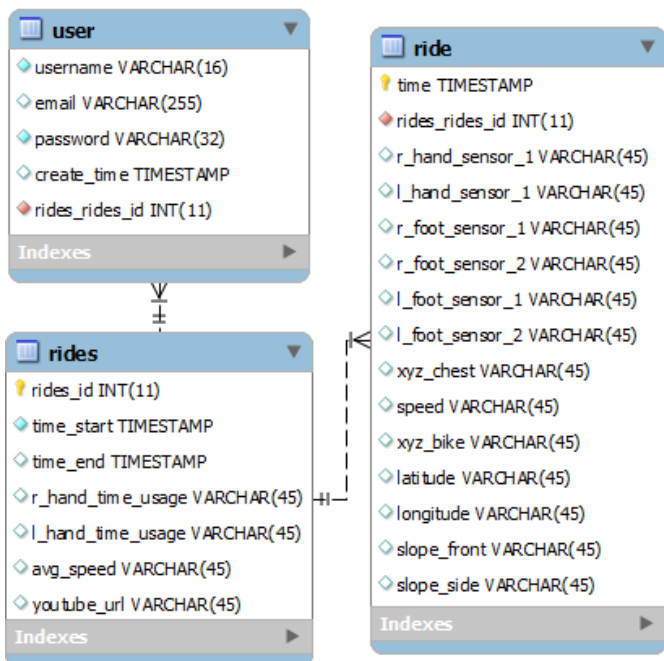

Figure 7 - Database model including Users, List of trainings (Rides) and training session (Ride) with all sensor data.

The functions implemented in PHP allow read and write to the database using HTTP requests. Some functions are LOGIN.php, GETRIDES.php and GETRIDE.php. Mobile application The mobile application was developed primarily targeting tablets with Android operating system version 4.2.0 (Jelly Bean). Taking into account the connection to the Cloud, the device necessarily requires internet connection either via WiFi or via mobile network (2G, 3G). The sequence of activities in an application is represented in the following diagram:

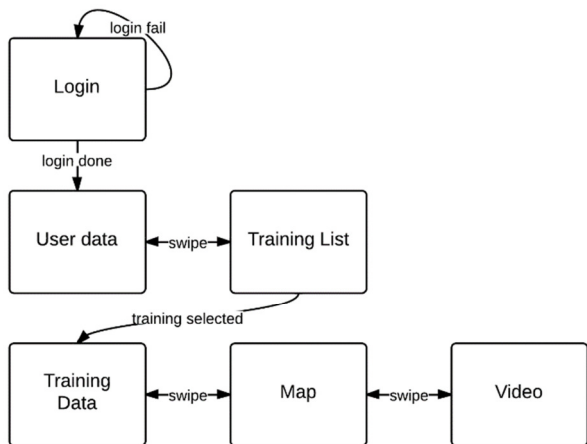

Figure 8 - Application sequence diagram

The login activity connects to the server and checks if the user exists and entered the credentials correctly, if "login done" starts a new activity that shows the user data through according with the collected information about training.

This information includes braking intensity data and frequency braking in each hand; pedal strength for each foot; rider body positioning and 3D bicycle oscillations.

The user can visualize the information for each training session by selecting one from the list, this selection will start a new activity that shows three tabs:

- Data Tab - This tab displays the data analyzed through graphs and also allowing the user to view detailed information about the raw data corresponding to the graph.
- Map Tab - This Tab allows the user to see the route of the train and points of interest, such as zone of maximum and minimum speed. A satellite view of the map is made using the API provided by google, called Google Maps Android API v2 [23].
- Video Tab - This Tab allows the user to see the YouTube video (if recorded) after the user enters the ID of the video in the application. The video view is made using the API provided by google, called YouTube Android Player API [24].

VI. RESULTS

For the tests of the individual nodes and WSN, an application was developed in Java using Processing. This application runs on a PC with an XBee Explorer that receives all the information of network nodes placed in shoes and gloves (Figure 9), and allows their visualization in real time as well as its storage in a file that can later be analyzed in a spreadsheet application such as Excel.



Figure 9 - Shoe and Glove force sensors

The prototype is still being assembled but we have collected some exemplar data. Exploratory data collection was performed using force sensors in right foot and right hand.

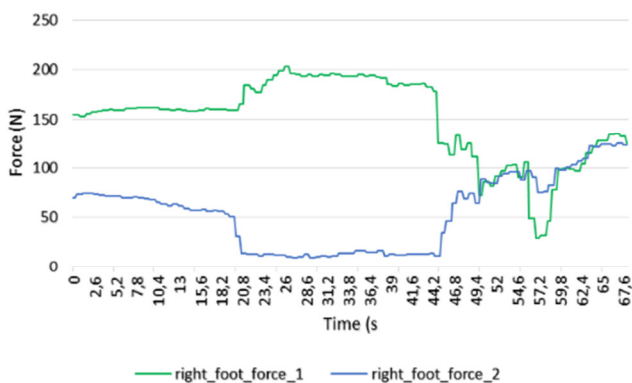

Figure 10 – Force evolution while rider is mounted on the bike testing variations in horizontal slope

Data collection was performed with the rider on the bike, and varying the bike inclination on the sagittal plan of motion under three conditions: i). bike with upright position; ii) bike tilted to the right; iii) bike tilted to the left.

The following data chart display rider behavior with the bike stopped in upright position. Due to no brakes action the red line remains with values close to 0. It is worth noting that due to the rider behavior to maintain a stable position on the bike the sensors from both feet capture fluctuations in the force produced.

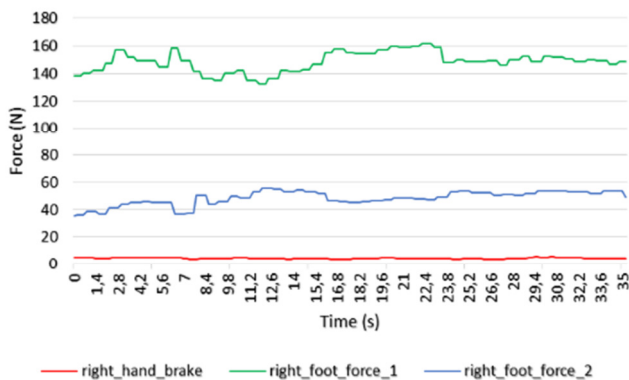

Figure 11 - Force evolution while rider is mounted on the bike stable

The results correspond for the rider sitting on the bike and the right hand on the brake, testing multiple braking action. Data display the magnitude and frequency of several force peaks which correspond to the different braking events.

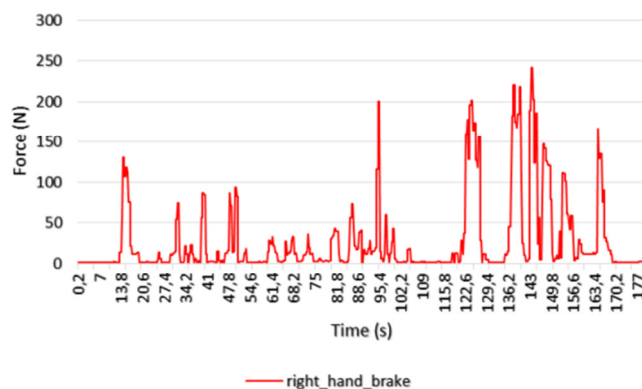

Figure 12 - Force evolution applied by the fingers for multiple breaking tests

The mobile application is still in development but already has some active features, such as geographic information system (Figure. 13) and an embedded YouTube video player (Figure 14).

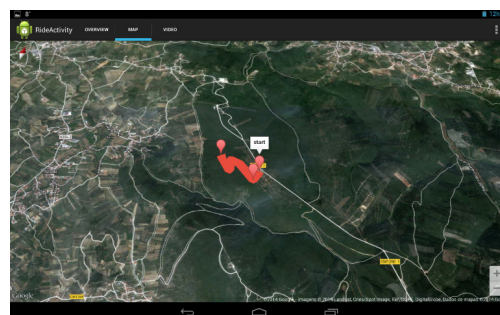

Figure. 13 - App geographic information system

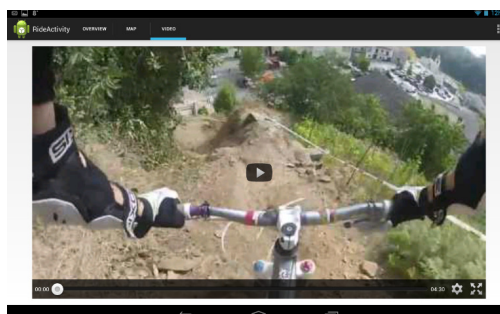

Figure 14 - APP embedded YouTube video player

Some tests are being done to determine what the best type of chart to display the information collected and analyzed. In Figure 15, we have an example of a pie chart on the use of brakes, comparing the left hand with the right hand.



Figure 15 - App chart type test, hands usage information

VII. CONCLUSIONS AND FUTURE WORK

In the paper the general architecture hardware and software of smart mountain bike prototype is presented including elements of WSN for force, direction acceleration measurement during the training session. An appropriate database model was considered and presented. Elements of the trainer system interaction based on mobile application are also presented. Force acceleration data acquired from different training session are used to calculate the training parameters that may include the force and breaking frequency. Extended tests are parts of the ongoing work.

ACKNOWLEDGEMENTS

This work was supported by the Instituto de Telecomunicações and Fundação para a Ciência e Tecnologia. Special acknowledgement is granted.

REFERENCES

- [1] S. B. L. in U. of California, "Instrumented Bicycle — Sports Biomechanics Lab." [Online]. Available: <http://biosport.ucdavis.edu/research-projects/bicycle/instrumented-bicycle> [Accessed: 20-Jan-2014]
- [2] D. Lie and C.-K. Sung, "Synchronous brake analysis for a bicycle," *Mech. Mach. Theory*, vol. 45, no. 4, pp. 543–554, Apr. 2010
- [3] N. W. Bergmann, M. Wallace, E. Calia, I. Superiore, and M. Boella, "Low Cost Prototyping System for Sensor Networks," pp. 19–24, 201
- [4] C. Bujdei and S. A. Moraru, "A low cost framework designed for monitoring applications, based on Wireless Sensor Networks," *2012 13th Int. Conf. Optim. Electr. Electron. Equip.*, 2012, pp. 1211–1220.
- [5] M. G. Rodriguez, L. E. O. Uriarte, Y. Jia, K. Yoshii, R. Ross, and P. H. Beckman, "Wireless Sensor Network for Data-Center Environmental Monitoring," 2014, pp. 533–537.
- [6] C. Yu, Y. Cui, L. Zhang, and S. Yang, "ZigBee Wireless Sensor Network in Environmental Monitoring Applications," *2009 5th Int. Conf. Wirel. Commun. Netw. Mob. Comput.*, pp. 1–5, Sep. 2009
- [7] X. H. Le, S. Lee, P. Tran, H. Truc, L. T. Vinh, A. M. Khattak, M. Han, V. Hung, M. M. Hassan, M. H. Kim, K. Koo, Y. Lee, and E. Huh, "Secured WSN-integrated Cloud Computing for u-Life Care," 2010 pp. 1–2.
- [8] N. S. A. Zulkifli, F. K. C. Harun, and N. S. Azahar, "XBee Wireless Sensor Networks for Heart Rate Monitoring in Sport Training," *Proceedings of International Conference on Biomedical Engineering (ICoBE)*, 2012, pp. 441 - 444 .
- [9] R. In, "M2M: From Mobile to Embedded Internet," April, 2011, pp. 36–43.
- [10] E. N. Barnhart and C. a. Bokath, "Considerations for Machine-to-Machine communications architecture and security standardization," *2011 IEEE 5th Int. Conf. Internet Multimed. Syst. Archit. Appl.*, Dec. 2011., pp. 1–6.
- [11] Y. Chen, "S7-1 Challenges and Opportunities of Internet of Things S7-1," 2012, pp. 383–388.
- [12] G. K. Thiruvathukal and M. Parashar, "Cloud Computing [Guest editorial]," *Comput. Sci. Eng.*, vol. 15, no. 4, Jul. 2013m, pp. 8–9.
- [13] A. Alamri, W. S. Ansari, M. M. Hassan, M. S. Hossain, A. Alelaiwi, and M. A. Hossain, "A Survey on Sensor-Cloud: Architecture, Applications, and Approaches," *Int. J. Distrib. Sens. Networks*, vol. 2013, pp. 1–18.
- [14] G. Anthes, "Invasion of the mobile apps," *Commun. ACM*, vol. 54, no. 9, Sep. 2011, p. 16.
- [15] W. Coldwell, "The 10 Best iPhone and Android cycle apps - Features - Gadgets & Tech - The Independent." 2013. [Online]. Available: <http://www.independent.co.uk/life-style/gadgets-and-tech/features/the-10-best-iphone-and-android-cycle-apps-8567728.html>, Jan-2014.
- [16] Pololu "MiniMU-9 v3 Gyro, Accelerometer, and Compass (L3GD20H and LSM303D Carrier)." Available at: <http://www.pololu.com/product/2468/resources>, 2014.
- [17] Atmel, "ATmega328P," 2014. Available at: <http://www.atmel.com/devices/atmega328p.aspx?tab=overview>. 2014.
- [18] Texas Instruments Incorporated, "AM3358 | AM335x Processors | ARM Cortex-A8 Core | Description & parametrics." Available at: <http://www.ti.com/product/am3358>, 2014.
- [19] Tekscan, "FlexiForce® Force Sensors | Single Button Force Sensing Resistor | Tekscan." Available at: <http://www.tekscan.com/flexible-force-sensors#third>, 2014.
- [20] Digi International Inc., "XBee® 802.15.4 - Digi International." Available online: <http://www.digi.com/products/wireless-wired-embedded-solutions/zigbee-rf-modules/point-multipoint-rfmodules/xbec-series1-module>. 2014.
- [21] Ed Callaway, "Low Power Consumption Features of the IEEE 802.15.4/ZigBee LR-WPAN Standard," 2003. Available online: <http://sensys.acm.org/2003/sensys03-callaway.pdf>, 2014.
- [22] "Tekscan® A201-100 - Advantac System." Available online: http://www.advanticsys.com/wiki/index.php?title=Tekscan®_A201-100, 2014.
- [23] Google, "Google Maps Android API v2 — Google Developers." Available online: <https://developers.google.com/maps/documentation/android/?hl=fr-FR>. 2014.
- [24] "YouTube Android Player API - YouTube — Google Developers." Available online: <https://developers.google.com/youtube/android/player/>, 2014.